



Operating Instructions for

DATA CASSETTE RECORDER

Model No. ANF - 03

LOCATION AND FUNCTION OF CONTROLS

NB : The Recorder is supplied with clear protective film on the labels around items (9) and (11). This may be peeled off.

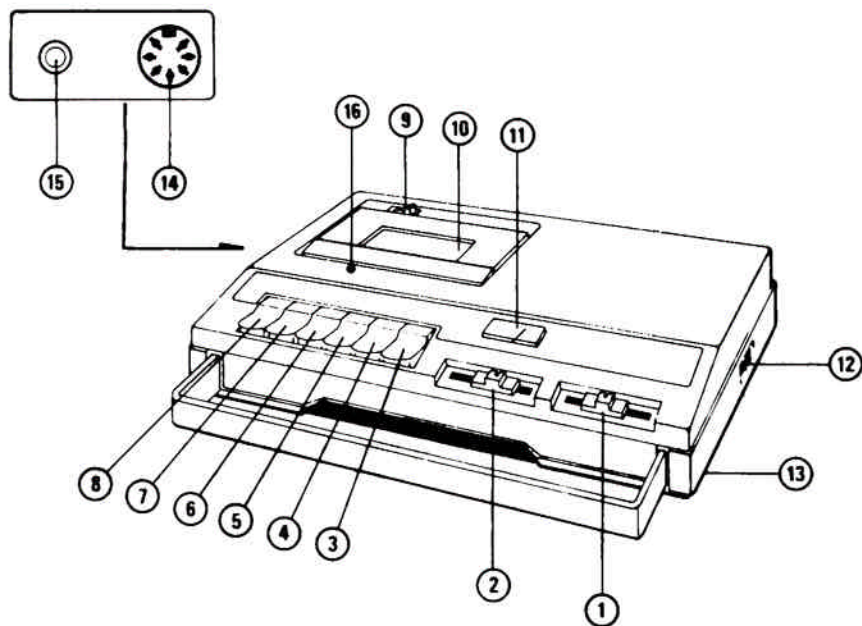

1. Tone Control
2. Volume Control
3. Pause Key
4. Stop/Eject Key
5. Play Key
6. Fast Forward Key
7. Rewind Key
8. Record Key

9. Tape Counter
10. Cassette Compartment
11. Battery/Level Meter
12. A.C. Mains Socket
13. Battery Compartment
14. Aux DIN Socket
15. Earphone Socket
16. Azimuth Adjustment
(Please consult your dealer)

IMPORTANT

The wires in the mains supply lead that connect to the terminals inside the mains plug are coloured in accordance with the following code : –

BLUE – Neutral

BROWN – Live

If the wire colours in this mains lead do not correspond with the terminal identification of your plug, connect as follows : –

BLUE wire to terminal coded 'N' (Neutral) or BLACK

BROWN wire to terminal coded 'L' (Live) or RED

Do not make any connection to the larger terminal coded 'E' or coloured GREEN or GREEN & YELLOW.

A fused plug must be fitted with a 3 AMP fuse approved to BS1362. When using a non-fused plug the equipment must be protected by a fuse at the main distribution board. This fuse must not exceed 5 AMP.

If in doubt consult a competent electrician.

WARNING

Disconnect from the mains at the wall socket when not in use. Do not remove the cover without first disconnecting the mains supply.

It is dangerous to operate this set or any other portable appliance from mains in a bathroom or close to water taps.

Do not expose this appliance to rain or moisture.

Do not use this equipment if for any reason water has been allowed to come into contact with any part of it. Place the unit in a dry and warm atmosphere and allow sufficient time for it to dry out completely. If in doubt consult your dealer.

NEVER let children push anything into holes or slots in the case - this could result in an electric shock.

PRECAUTIONS

When the set is not to be used for a long period of time or to be operated extensively on AC source, remove the batteries to avoid damage from battery leakage.

Do not install the set in a location near heat sources such as radiators or airducts, or in a place subject to direct sunlight, excessive dust, mechanical vibration, or shock.

POWER SUPPLY

A. Mains Operation

- Plug the AC mains lead into the AC Mains Socket (12). Insertion of the plug into this socket automatically disconnects the internal batteries.
- Connect the mains lead to the mains and switch on.
WARNING. Disconnect from the mains socket when not in use.
- The ANF-03 will now operate using the mains supply. In order to extend battery life, always use the mains when a mains socket is within reach.

B. Battery Operation

- Place the set face down on a flat surface, and remove battery cover.
- Insert 4 pieces HP11 battery or equivalent, carefully observing correct polarity as indicated in the battery compartment.
- Replace the battery cover.
- To test the condition of the batteries depress Play Cassette Key (5). If the indicator of the Battery/Level Meter (11) registers within the red zone, batteries are satisfactory, if not they should be removed and replaced with new cells.

INTERFACE BETWEEN DATA CASSETTE RECORDER AND MICRO-COMPUTER

- Connect the 7 pin DIN lead from the DIN Socket (14) of the Data Cassette Recorder to the Cassette Socket of the Microcomputer, when the Recorder motor (Stop/Start) will be controlled by the computer.

CASSETTE INSERTION

- Before inserting a cassette, check the tape tension and make sure that any slack is taken up. This can be done by inserting a pencil into one of the hub holes and turning to take up the slack. This simple operation will prevent tape-spill and loop-throwing both of which can physically damage the tape and spoil recordings.

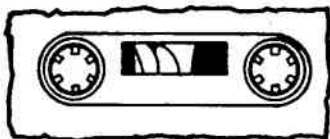

Fig.1

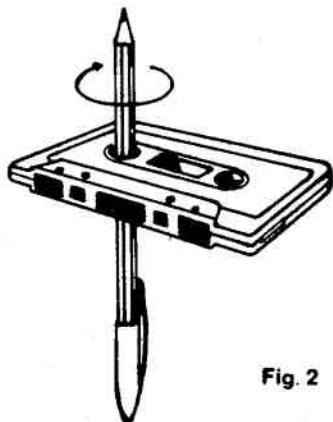

Fig. 2

- Press the Stop/Eject Key (4) to open cassette holder.
- Place the cassette in the holder, insert the cassette with the desired side, A or B, uppermost.
- Close the holder by pressing down firmly to ensure cassette is correctly located.
- To take out the cassette, press the Stop/Eject Key (4).

NOTE

- C15 data cassette or C30 or C60 cassettes should be used. (The use of C120 cassettes is not recommended with this machine).
- Do not attempt to load a cassette when the mechanism is engaged.
- Do not attempt to remove a cassette without first disengaging any function by using the Stop/Eject Key (4).

SAVING PROGRAMS ON A CASSETTE FROM THE COMPUTER

- Insert a cassette - see Cassette Insertion — and refer to the Microcomputer System USERS GUIDE, Recording Programs on Cassette.
- Press the Record Key (8) and Play Key (5) simultaneously until locked. The tape will then start recording and the Record Level Meter will begin to flicker. During recording, the recording level is automatically adjusted for optimum results by the Automatic Level Control (ALC) Circuit.
- To stop recording completely, press the Stop Key (4). If the end of the tape is reached while recording, your recorder will shut off automatically. The Record Key and Play Key will also be released from their locked positions.
- When the computer has finished saving the program on the tape the recorder will automatically stop. If further recording is not required the Stop Key (4) on the recorder should be pressed to unload the head mechanism.

NOTE

- To enable the user to know that the program is being recorded a fixed level monitor tone can be heard. If not required mute by inserting the earpiece plug into Earphone Socket (15).

LOADING PROGRAMS INTO COMPUTER FROM CASSETTE DATA STORAGE SYSTEM

- Refer to the Microcomputer System USERS GUIDE Loading programs from cassette.
- Insert a recorded cassette into the Cassette Compartment (10).
- Press the Play Key (5) until it locks, and the tape will start running.
- When playback is finished, press the Stop Key (4).
- When the tape reaches its end during playback, the tape drive mechanism is released and the power is turned off automatically. The Play Key is also released from its locked position.
- In the Play mode the Computer operation automatically controls tape start/stop procedure.
- Adjustment of the Volume Control (2) in this procedure is not necessary since the signal levels are independent of the Volume Control.
- The Volume Control (2) may be set as required for audible monitoring.

FAST FORWARD AND REWIND

- When connected to the computer these functions can be operated by typing Save or Load and depressing the Fast Forward or Rewind Keys.
- To advance the tape rapidly, press the Fast Forward Key (6). To stop the tape, press the Stop Key (4).
- To rewind the tape quickly, press the Rewind Key (7). To stop the tape, press the Stop Key (4).
- Attempting to go from either the F.F. or rewind modes without first stopping the tape is likely to damage the tape and may cause damage to the mechanism.
- When the end of the tape is reached press Stop Key (4) to dis-engage.

USE OF TAPE COUNTER

- When recording from the beginning of a tape, set the Tape Counter (9) to the '000' position by pressing the Counter Reset Button. The tape counter shows the positions of sections recorded on the tape while it is being played so that you may locate those sections again during playback.

EARPHONE SOCKET

- An earphone may be connected to the Earphone Socket (15) for private listening or monitoring. Insertion of the earphone automatically disconnects the built-in speaker. The impedance of the earphone must not be less than 8 ohms.

PROTECTION AGAINST ACCIDENTAL ERASURE

- Normally, anything recorded on the tape is automatically erased when a new recording is made.
- It is possible to protect your recordings from accidental erasure by removing the erase-lock tabs found on the rear of the cassette.
- When the cassette is held with the recorded side uppermost, the protective tab will be found on the left of the rear edge of the cassette.
- All pre-recorded cassettes are protected in this way to prevent accidental erasure of the commercial recording.
- "Protected" cassettes may be re-recorded simply by fixing a piece of adhesive tape over the hole where the tab has been removed. This takes place of the tab and your machine can now be engaged in the record mode. A "protected" cassette will prevent the record button from being depressed. If at any time you attempt to record, and this button will not engage, never force the mechanism or damage will result. Check that a cassette has been loaded properly and that the erase-lock tab has not been removed.

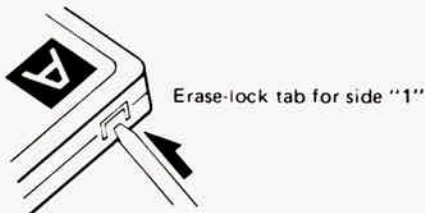

STORING THE CASSETTE

- Replace the cassette in its protective holder immediately after use to protect it from dust and to prevent the tape from being unwound in the cassette. Store in a cool, dry place away from direct sunlight and strong magnetic fields such as speakers and electric motors.

CAUTION

- When the tape reaches its end during fast forward or rewind operation it stops automatically but the motor remains running. Be sure to stop the motor by pressing the Stop Key (4) or otherwise the tape drive mechanism may be damaged.
- Keep the machine and cassettes away from strong magnetic fields, such as close to large transformers, electric motors, television receivers and loudspeakers.
- Do not make excessive use of the Fast Forward and Rewind buttons in searching for a particular item on a cassette; this may cause "stepping" or ridges in the layers of tape and thus cause jamming, triggering the autostop.
- Do not touch recording head with screw-driver or other metallic or magnetic objects.

MAINTENANCE OF THE CASSETTE MECHANISM

- The parts of the machine coming into direct contact with the tape do require periodic cleaning to ensure continuing good performance.
- The tape heads (erase head, record/play head) should be cleaned using a cotton bud moistened with a drop of isopropyl alcohol solution or proprietary tape head cleaner or, alternatively, by a good quality Tape Head Cleaning cassette.
- The pinch-roller and capstan shaft may be cleaned in a similar manner.
- To gain better access to these parts of the mechanism, remove any cassette from the compartment and leave the compartment door open. Pressing the Play Key (5) will engage the mechanism and move all parts into view.
- It will be found easier to clean the pinch-roller if the power source is connected (batteries or mains) so that the roller and the capstan shaft rotate.
- Failure to maintain the tape heads in a clean condition will result in program errors and incomplete erasure.
- Failure to maintain the pinch-roller and capstan shaft in a clean condition is likely to cause the tape to entangle and spill out of the cassette.

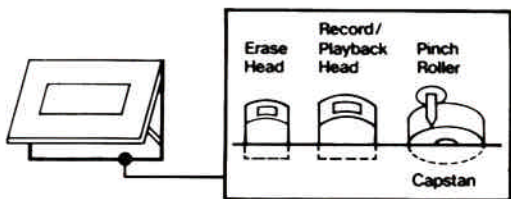

DEMAGNETIZING THE HEAD

Either prolonged use or an accidental contact with a piece of magnetized steel (screwdriver, scissors, etc) will magnetize the Record/Playback Head causing an increase in tape noise. In such an event, demagnetize the head using a commercially available head demagnetizer.

- Be careful not to demagnetize the Erase Head.
- When demagnetizing, remove the batteries and disconnect the AC power cord.

CLEANING THE CABINET

- Clean the cabinet with a soft cloth slightly moistened with water or a mild detergent solution. Do not use solvents such as alcohol, benzene, or thinners as they may damage the finish of the cabinet.

PREPARING THE UNIT FOR NORMAL AUDIO USE

For use as a monaural cassette unit, i.e. for normal record and playback of music or speech, it will be necessary to make up a separate connecting lead to that used with the computer. The connections required at the cassette end of the lead should be made as indicated in the drawing below:-

A. When the input is from a stereo source connect as follows:-

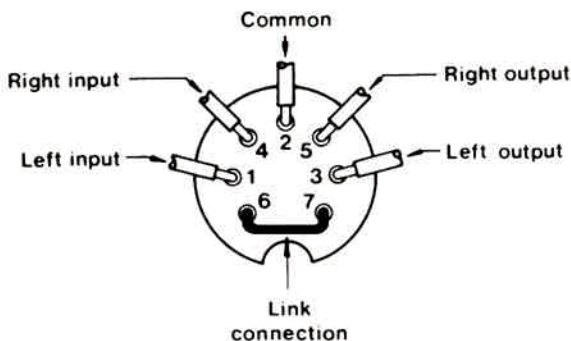

B. When the input is from a monaural source:-

- Connect input lead to either pins 1 or 4.
- Connect output lead to either pins 3 or 5.
- Connect common lead to pin 2.
- The link wire connecting pins 6 and 7 is also required.

PRODUCT SPECIFICATION

1. EQUIPMENT : Data Cassette Recorder
2. ORDER CODE : ANF-03
3. FUNCTION : Program and data storage on C5 upto C90 type audio cassette tape
4. DESCRIPTION OF OPERATION : Mono cassette recorder with motor control facility
Auto stop on play and record
Fixed level audible monitor on record
Variable level audible monitor on playback
does not affect signal to computer
Usable for audio but no microphone facilities
5. CAPACITY : Approx. 30 Kbytes/side on C15
Approx. 120 Kbytes/side on C60
6. FORMAT : 300 or 1200 baud computer user tape standard 1200 and 2400 Hz tones
7. SPEED : 4.75 cm/second -2% to $+3\%$
Fast forward and rewind in 100 seconds for C60
8. CONTROLS : 6 key mechanism for "pause", "play", "stop and eject", "fast forward",
"rewind" and "record"
Slider controls for volume and tone
9. INDICATORS : Record Level/battery level meter (-20 to $+3$ dB)
Tape position counter with reset button
Audible monitor
10. SIGNAL CONNECTIONS : 7 pin DIN for input/output/motor control (motor
controlled when plugged into computer)
Input signal range from -20 dB to $+10$ dB
(0dB = 60mV RMS)
Output signal 275mV RMS fixed
3.5mm loudspeaker/earphone jack socket (mutes
speaker when inserted)
11. POWER IN : 240V, 50Hz AC, 8 watts OR 4 x HP11 1.5 volt cells
12. APPROVALS : To conform to BS415 : 79
13. OPERATING TEMPERATURE : Designed to work within the following temperatures
 -10 to $+45^{\circ}\text{C}$
14. ACCESSORIES INCLUDED : Earpiece with 3.5mm jack plug (to mute speaker)
7 pin DIN to DIN lead, 2 core mains lead.
User Manual

Acorn Computers Limited
Fulbourn Road, Cherry Hinton,
Cambridge CB1 4JN.

© Copyright Acorn Computers Limited 1984

Neither the whole or any part of the information contained in this manual may be adopted or reproduced in any material form except with the prior written approval of Acorn Computers Limited (Acorn Computers).

The product described in this manual and products for use with it, are subject to continuous development and improvement. All information of a technical nature and particulars of the product and its use (including the information and particulars in this manual) are given by Acorn Computers in good faith. However, it is acknowledged that there may be errors or omissions in this manual. A list of details of any amendments or revisions to this manual can be obtained upon request from Acorn Computers Technical Enquiries. Acorn Computers welcome comments and suggestions relating to the product and this manual.

All correspondence should be addressed to:—

Technical Enquiries
Acorn Computers Limited
Fulbourn Road
Cherry Hinton
Cambridge
CB1 4JN

All maintenance and service on the product must be carried out by Acorn Computers authorised dealers. Acorn Computers can accept no liability whatsoever for any loss or damage caused by service or maintenance by unauthorised personnel. This manual is intended only to assist the reader in the use of the product, and therefore Acorn Computers shall not be liable for any loss or damage whatsoever arising from the use of any information or particulars in, or any error or omission in, this manual, or any incorrect use of the product.